

## Series 17 Chain Wheels

### Introduction

The Series 17 Chain Wheels provide ground-level manual opening & closing of overhead valves. They are easily installed on Flow Line Controls Series 15 Gear Operators or other manufacturers gear operators and replace the standard handwheel. The Series 17 Chain Wheels use welded link chain that does not have sharp edges or burrs that can cause injury. Flow Line Controls installs chain cut to customer specified lengths.

### Specifications

#### Wheel Materials

Sprocket & Hub: ductile iron  
Bracket: steel  
Hardware: steel

#### Weights

17-32200: 12 pounds  
17-32290: 20 pounds  
17-32410: 38 pounds

#### Chain

Type: straight coil, welded link, smooth edge  
Length: customer specified length  
Materials: zinc coated steel

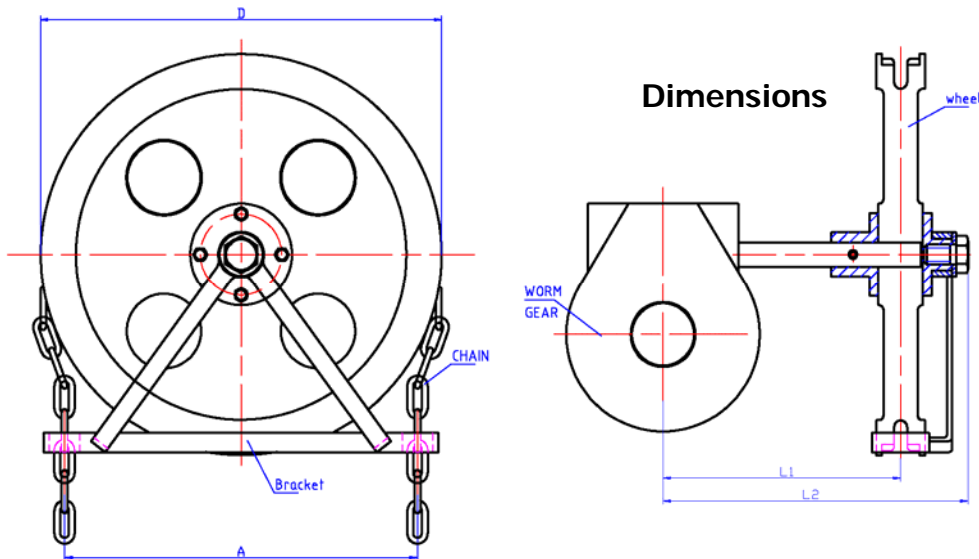

| PART #   | USE WITH GEAR OPERATOR PART # | D      | L1     | L2     | A      | SHAFT BORE* |
|----------|-------------------------------|--------|--------|--------|--------|-------------|
| 17-32200 | 15-00202 15-00225 15-00203    | 7.87"  | 3.62"  | 5.62"  | 7.08"  | 0.629"      |
|          | 15-00204 15-00205 15-00206    | 200 mm | 92 mm  | 143 mm | 180 mm | 16 mm       |
| 17-32290 | 15-00208 15-00210             | 11.41" | 6.41"  | 8.46"  | 10.62" | 0.748"      |
|          | 15-00212 15-00214             | 290 mm | 163 mm | 215 mm | 270 mm | 19 mm       |
| 17-32410 | 15-00216 15-00218             | 16.14" | 10.10" | 12.32" | 14.96" | 0.984"      |
|          | 15-00220 15-00224             | 410 mm | 257 mm | 313 mm | 380 mm | 25 mm       |

\*Standard shaft bore sizes, custom sizes available