

Dimensions

Series 15 Gear Operator
 Size: 15-00204, 15-00206,
 and 15-00210

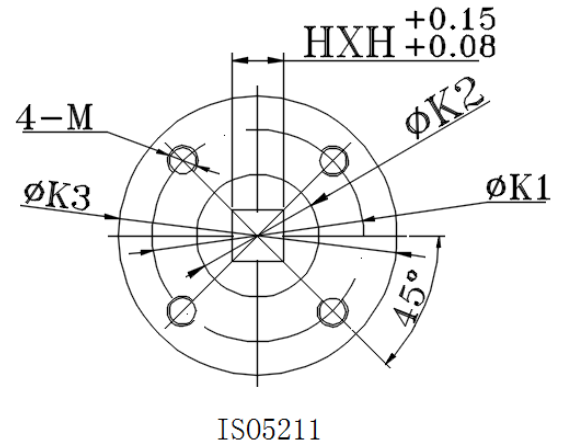
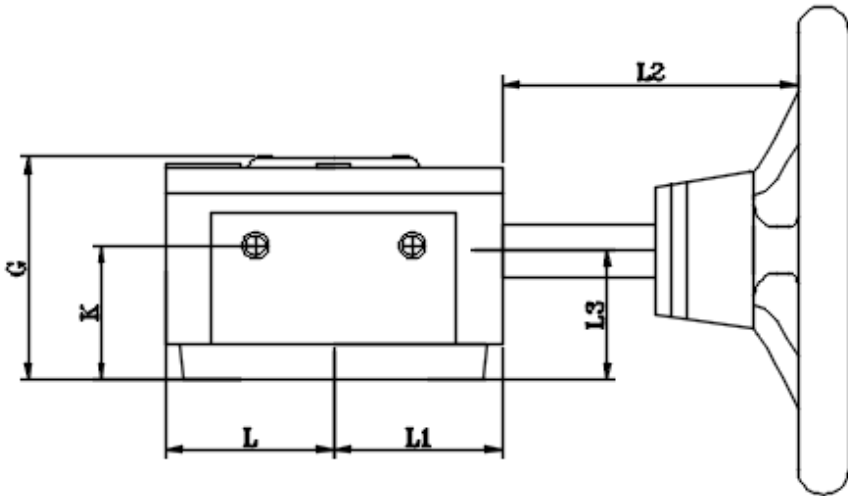

IS05211

DIMENSIONS ARE INCHES UNLESS NOTED

Drawn By: DAP
 Revision: A
 Date: 3-1-2016

