

Size	L	D	D1	Y	T	f	Z	U	D2	d	Q	Z - UNC/UN
10"	8.46	11.02	8.66	3.82	6.89	0.16	2.95	3.94	1.26	0.40	5.51	4-UNC 3/4"-10
12"	9.25	12.60	9.84	4.41	8.27	0.16	3.15	5.12	1.42	0.40	6.50	4-UNC 3/4"-10
14"	9.84	13.78	10.83	4.41	8.27	0.16	3.54	5.12	1.57	0.40	6.50	4-UNC 3/4"-10

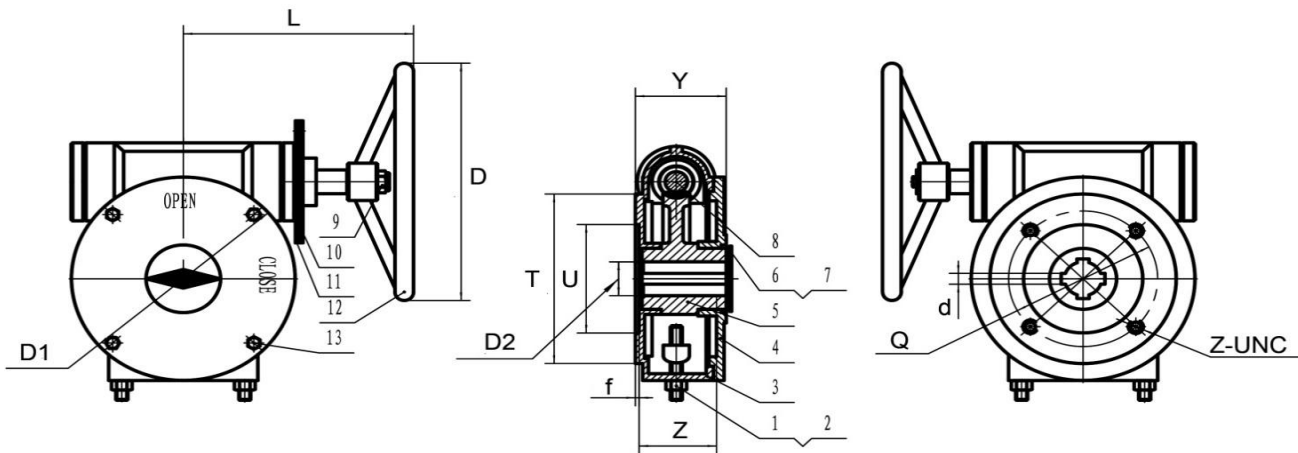

No.	PART	QTY	MATERIAL
1	Adjusting Screw	2	SS316
2	Nut	2	SS316
3	Worm Gear Box	1	CF8M
4	Cover	1	CF8M
5	Worm Gear	1	C95800
6	Dial	1	SS316
7	Bolts	2	SS316
8	Worm Gear Shaft	1	SS316
9	Handwheel Lock Nut	1	SS316
10	End Cap	1	SS316
11	Locking Plate	2	SS316
12	Handwheel	1	SS316
13	Bolts	4	SS316

Pressure Rating:	DIMENSIONAL DATA SHEET Series 15N Worm Gear Operator SS Body / Bronze Worm Gear 10" - 14" Specification MIL-V-24624 Shock MIL-S- 901D Grade A Vibration Test MIL-STD-167-1A	Material Reference:
Customer/Project:		SS316
Cage Code:		Part No.:
6SPR5	Specification MIL-V-24624	15-N46XX
Drawn By:	Approved by:	Drawing No.:
TEM	DAB	FL 15N-02SS-R7
		Rev. #
		J
		Rev. Date
		03/11/15