



Technical Information

Model 30	Rated torque	Operating time 50/60Hz	Max bore size	Power consumption	Motor insulation class	Rate current (A)				No of handle turns	Wgt
						50/60Hz					
						1 Phase		3 Phase			
Size	Inch Pounds	90°	Inches	Watts		110V	220V	380V	440V	90°	lbs

Model 0020, 0050

0020	265	12/9	0.55	15	F	0.5	0.3	NA	NA	9	4.5
0050	531	20/14	0.55	15	F	0.5	0.3	NA	NA	9	4.5

Model 0080 to 0900

0080	885	21/18	0.9	15	F	0.95/1.05	0.50-0.55	N/A	N/A	10	15
0100	1,416	26/22	1.06	40	F	1.60/1.70	0.85/0.90	0.30/0.30	0.30/0.32	12	33
0200	2,124	26/22	1.06	40	F	1.62/1.72	0.87/0.92	0.32/0.32	0.32/0.34	12	33
0300	3,100	31/26	1.65	40	F	1.72/1.80	0.92/0.95	0.32/0.32	0.32/0.35	14	44
0400	4,425	31/26	1.65	90	F	3.60/3.90	1.30/1.60	0.52/0.56	0.55/0.58	14	44
0700	7,100	39/32	2.04	180	F	3.80/4.20	2.05/2.20	0.82/0.88	0.82/0.85	17	55
0900	9,800	39/32	2.04	180	F	3.90/4.30	2.15/2.30	0.84/0.90	0.84/0.88	17	55

Model 1300 to 2600

1300	13,277	93/78	3.07	180	F	3.60/3.90	1.30/1.60	0.52/0.56	0.55/0.58	42	155
1700	17,702	117/97	3.07	180	F	3.80/4.20	2.05/2.20	0.82/0.88	0.82/0.85	52	155
2600	26,600	117/97	3.07	180	F	3.90/4.30	2.15/2.30	0.81/0.90	0.84/0.88	52	155

Flow Line Controls, Inc.

Model 0020, 0050

Actuator Size	A	B	D	E	F	G	H	X	Y	Z	ISO Mounting
0020	M5 X 8	M6 X 8	14	35	50	1	16.5	121.8	113.5	129	F3 / F5
0050	M6 X 10	M8 X 12	14	50	70	1	16.5	121.8	113.5	165	F5 / F7

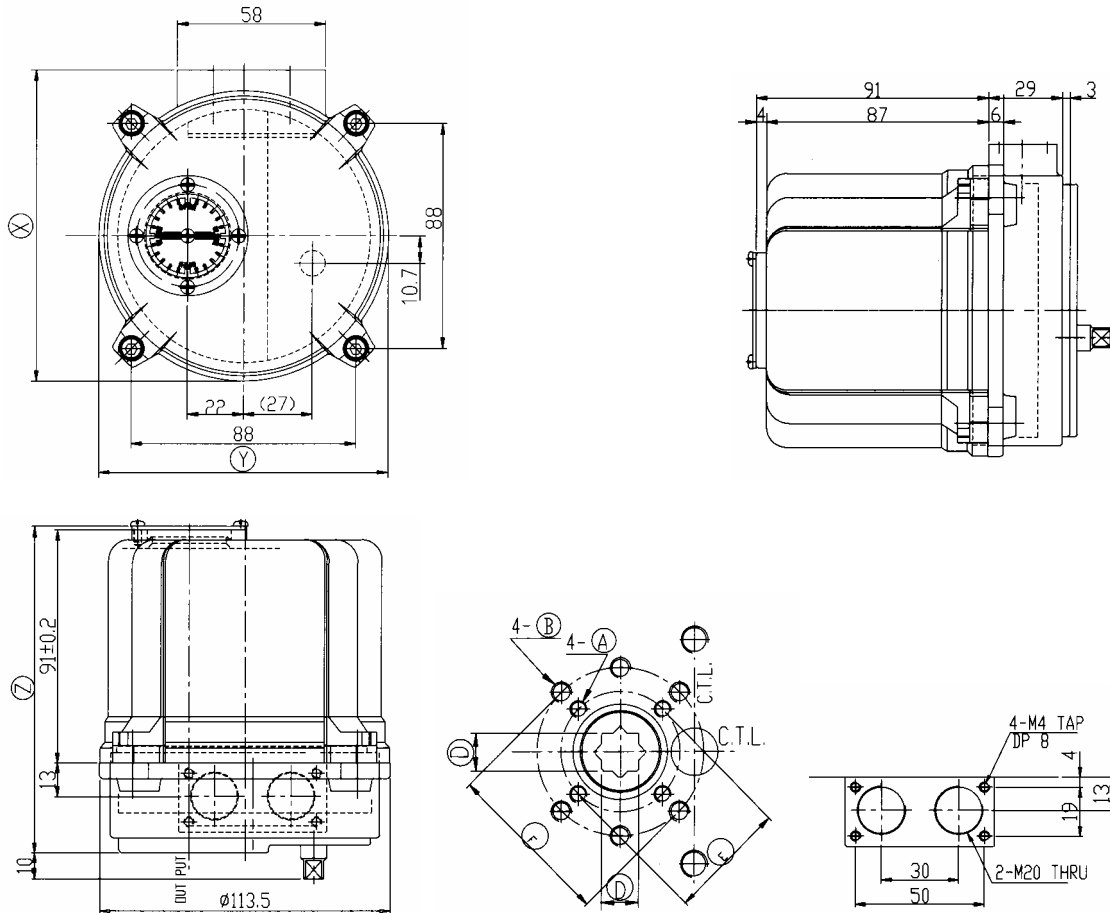

VALVE SIZE	DIMENSIONAL DATE SHEET ELECTRIC ACTUATOR SERIES 30 SIZES 0020, 0050	PART NO.	
VOLTAGE RATING		DRAWING NO.	REV
CUSTOMER/PROJECT		30-0020	A
INQ./PO NO.		DATE	
ORDER NO.		01-04-04	
CERTIFIED BY		DATE	

Model 0080 to 0400

Actuator Size	A	B	C	D (Key)	D (Sq.)	E	F	G	H	S	X	Y	Z	ISO Mounting
0080	M8	14	70	2.76	.79	1.97	3.45	.12	1.46	3.94	10.16	6.77	8.66	F7
0100	M8/M10	14/17	70	2.76	.91	2.30	4.92	.12	2.24	4.53	13.31	9.02	10.20	F7/F10
0200	M8/M10	14/17	70	2.76	.91	2.30	4.92	.12	2.24	4.53	13.31	9.02	10.20	F7/F10
0300	M10/M12	17/21	102	4.02	.91	3.15	5.83	.12	2.44	5.71	14.06	9.61	11.34	F10/F12
0400	M10/M12	17/21	102	4.02	1.34	3.15	5.83	.12	2.44	5.71	14.06	9.61	11.34	F10/F12

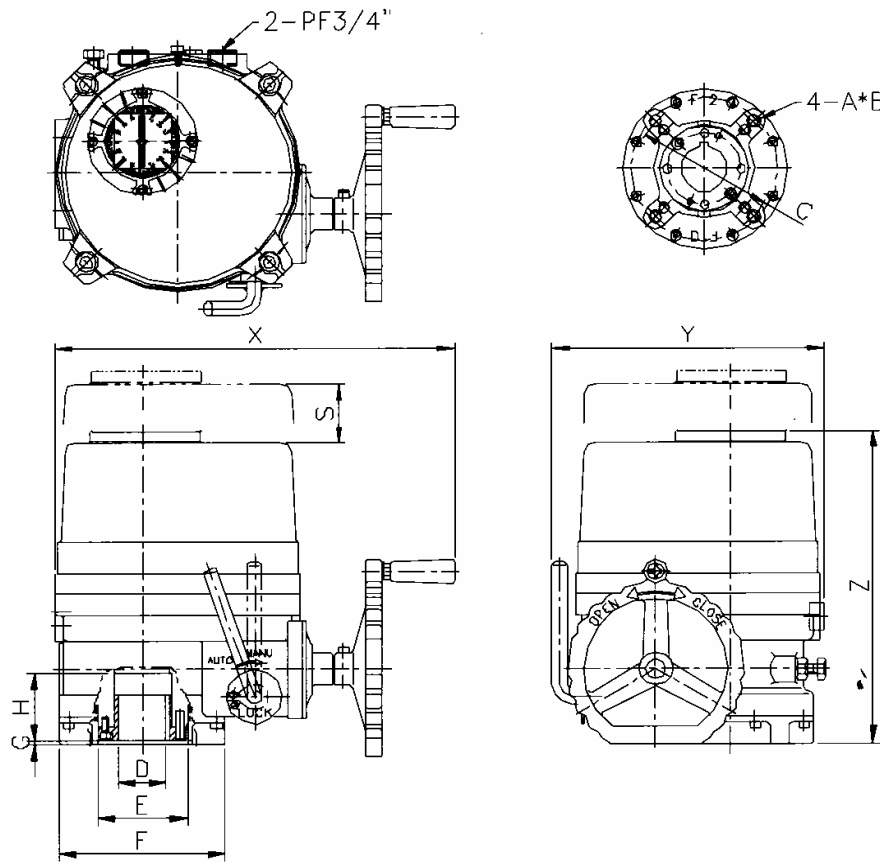

VALVE SIZE	DIMENSIONAL DATE SHEET ELECTRIC ACTUATOR SERIES 30 SIZES 0080 - 0400	PART NO.	
VOLTAGE RATING		DRAWING NO.	REV
CUSTOMER/PROJECT		30-0021	A
INQ./PO NO.		DATE	
ORDER NO.		01/04/04	
CERTIFIED BY DATE			